



Broil King®

LUXURY

NEW

TELL

US

ABOUT

LUXURY BUILT-IN

FINALLY A SMARTER CHOICE FOR GRILLING CENTERS

Broil King® gives you a new level of flexibility with the unique modular pod system. Broil King's Built-in series is a match of performance and luxury designed for the professional outdoor chef.

Utilize the pod system and add the Keg charcoal grill / smoker to create the ultimate outdoor grilling center. This series comes equipped with premium standout features like commercial-grade cast stainless steel cooking grids, a double-wall stainless steel cook box and patented stainless steel Dual-Tube™ burners.

Crafted with durable North American 304 grade stainless steel, the exterior is inspired by professional cooking appliances. Light up the night with back-lit control knobs and oven lights to instantly create the perfect ambiance at your next get together. Broil King®: the smart choice in outdoor grilling centers.





DESIGNED, ENGINEERED AND TESTED FOR GREAT BARBECUE FLAVOUR

Every Broil King® gas grill is designed and built to deliver great barbecue flavour. Broil King's Performance Grilling Technology (PGT) is a cooking system that is designed and engineered to vapourize food juices and deliver that great barbecue flavour every time you grill.

From the overall design of the cookbox, to the integration of how the cooking grids, Flav-r-Wave and burners work as a grilling system, Broil King® is a premium quality performance barbecue.





Broil King
PGTTM
PERFORMANCE GRILLING
TECHNOLOGY

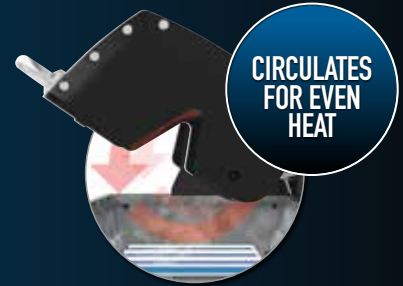

CIRCULATES
FOR EVEN
HEAT

**AMAZING
HEAT RETENTION**
CAST ALUMINUM AND STAINLESS
STEEL COOK BOX DESIGN



EXTRA-THICK
GRIDS HOLD
THE HEAT

**OUTSTANDING
SEARING POWER**
CAST STAINLESS STEEL AND CAST IRON
PROFESSIONAL-GRADE COOKING GRIDS



VAPORIZES
JUICES FOR
GREAT BBQ
FLAVOUR

**100% COVERAGE ACROSS THE
GRILL SURFACE FOR EVEN HEAT**
STAINLESS STEEL FLAV-R-WAVETM
COOKING SYSTEM



EVEN HEAT
FRONT TO BACK
AND SIDE TO
SIDE

**UNMATCHED
HEAT DISTRIBUTION**
DUAL-TUBETM BURNERS



SEARING,
ROASTING
OR SLOW
COOKING

**PRECISE TEMPERATURE
CONTROL EVERY TIME**
DELUXE ACCU-TEMPTM CONTROLS

IMPERIAL™ BUILT-IN STANDARD FEATURES

SIDE BURNER	2.7 kW commercial-grade side burner
ROTISSERIE BURNER	4.4 kW stainless steel rear rotisserie burner and premium rotisserie kit
COOKING GRIDS	Professional cast stainless steel cooking grids
FLAVOUR SYSTEM	304 stainless steel Flav-R-Wave™ cooking system
HEAT CONTROL	Linear-Flow™ valves with 180° Sensi-Touch™ control
THERMOMETER	Deluxe Accu-Temp™ thermometer(s)
IGNITION	Sure-Lite™ electronic ignition system
COOK BOX	304 stainless steel cook box with cast aluminum end caps
LID DESIGN	Roll-action lid(s) with cast aluminum end caps
HANDLES	Stylish and durable stainless steel handles
FINISH	Premium stainless steel finish
BUILT-IN LIGHTS	Built-in lights located in the cook box and control knobs



IMPERIAL™ S 690 BIC FEATURES

PERFORMANCE	17.6 kW main burner output
BURNERS	Six stainless steel Dual-Tube™ burners
COOK BOX	Two completely separate cook boxes
TOTAL COOK SPACE	6,645 sq cm total cooking space including two porcelain coated warming racks
LARGE COOK BOX	3,225 sq cm primary large cook box
SMALL COOK BOX	1,613 sq cm primary small cook box
COOK BOX LIDS	Two durable stainless steel lids





IMPERIAL™ S 590 BIC FEATURES

PERFORMANCE	16 kW main burner output
BURNERS	Five stainless steel Dual-Tube™ burners
TOTAL COOK SPACE	5,645 sq cm total cooking space including porcelain coated warming rack
PRIMARY COOK SPACE	4,032 sq cm primary cooking space
COOK BOX LID	Durable stainless steel lid



IMPERIAL™ S 490 BIC FEATURES

PERFORMANCE	12.8 kW main burner output
BURNERS	Four stainless steel Dual-Tube™ burners
TOTAL COOK SPACE	4,484 sq cm total cooking space including porcelain coated warming rack
PRIMARY COOK SPACE	3,226 sq cm primary cooking space
COOK BOX LID	Durable stainless steel lid

IMPERIAL™ BUILT-IN STANDARD FEATURES

SIDE BURNER	2.7 kW commercial-grade side burner
ROTISSERIE BURNER	4.4 kW stainless steel rear rotisserie burner and premium rotisserie kit
COOKING GRIDS	Professional cast stainless steel cooking grids
FLAVOUR SYSTEM	304 stainless steel Flav-R-Wave™ cooking system
HEAT CONTROL	Linear-Flow™ valves with 180° Sensi-Touch™ control
THERMOMETER	Deluxe Accu-Temp™ thermometer(s)
IGNITION	Sure-Lite™ electronic ignition system
COOK BOX	304 stainless steel cook box with cast aluminum end caps
LID DESIGN	Roll-action lid(s) with cast aluminum end caps
HANDLES	Stylish and durable stainless steel handles
FINISH	Premium stainless steel finish
BUILT-IN LIGHTS	Built-in lights located in the cook box and control knobs



INSULATING SLEEVE
BUILT INTO EVERY BROIL KING®
GRILL HEAD FOR ADDED
SAFETY AND VALUE



IMPERIAL™ S 690 BI FEATURES

PERFORMANCE	17.6 kW main burner output
BURNERS	Six stainless steel Dual-Tube™ burners
COOK BOX	Two completely separate cook boxes
TOTAL COOK SPACE	6,645 sq cm total cooking space including two porcelain coated warming racks
LARGE COOK BOX	3,225 sq cm primary large cook box
SMALL COOK BOX	1,613 sq cm primary small cook box
COOK BOX LIDS	Two durable stainless steel lids



IMPERIAL™ S 590 BI FEATURES

PERFORMANCE	16 kW main burner output
BURNERS	Five stainless steel Dual-Tube™ burners
TOTAL COOK SPACE	5,645 sq cm total cooking space including porcelain coated warming rack
PRIMARY COOK SPACE	4,032 sq cm primary cooking space
COOK BOX LID	Durable stainless steel lid



IMPERIAL™ S 490 BI FEATURES

PERFORMANCE	12.8 kW main burner output
BURNERS	Four stainless steel Dual-Tube™ burners
TOTAL COOK SPACE	4,484 sq cm total cooking space including porcelain coated warming rack
PRIMARY COOK SPACE	3,226 sq cm primary cooking space
COOK BOX LID	Durable stainless steel lid

IMPERIAL™ BUILT-IN STANDARD FEATURES

ROTISSERIE BURNER	4.4 kW stainless steel rear rotisserie burner and premium rotisserie kit
COOKING GRIDS	Professional cast stainless steel cooking grids
FLAVOUR SYSTEM	304 stainless steel Flav-R-Wave™ cooking system
HEAT CONTROL	Linear-Flow™ valves with 180° Sensi-Touch™ control
THERMOMETER	Deluxe Accu-Temp™ thermometer(s)
IGNITION	Sure-Lite™ electronic ignition system
COOK BOX	304 stainless steel cook box with cast aluminum end caps
LID DESIGN	Roll-action lid(s) with cast aluminum end caps
HANDLES	Stylish and durable stainless steel handles
FINISH	Premium stainless steel finish
BUILT-IN LIGHTS	Built-in lights located in the cook box and control knobs



IMPERIAL™ S 670 BI FEATURES

PERFORMANCE	17.6 kW main burner output
BURNERS	Six stainless steel Dual-Tube™ burners
COOK BOX	Two completely separate cook boxes
TOTAL COOK SPACE	6,645 sq cm total cooking space including two porcelain coated warming racks
LARGE COOK BOX	3,225 sq cm primary large cook box
SMALL COOK BOX	1,613 sq cm primary small cook box
COOK BOX LIDS	Two durable stainless steel lids





IMPERIAL™ S 570 BI FEATURES

PERFORMANCE	16 kW main burner output
BURNERS	Five stainless steel Dual-Tube™ burners
TOTAL COOK SPACE	5,645 sq cm total cooking space including porcelain coated warming rack
PRIMARY COOK SPACE	4,032 sq cm primary cooking space
COOK BOX LID	Durable stainless steel lid



IMPERIAL™ S 470 BI FEATURES

PERFORMANCE	12.8 kW main burner output
BURNERS	Four stainless steel Dual-Tube™ burners
TOTAL COOK SPACE	4,484 sq cm total cooking space including porcelain coated warming rack
PRIMARY COOK SPACE	3,226 sq cm primary cooking space
COOK BOX LID	Durable stainless steel lid

IMPERIAL™ 600 SERIES | 6,645 SQ-CM TOTAL GRILLING AREA

STAINLESS STEEL WARMING RACK - 1,807 SQ-CM



CAST STAINLESS GRIDS - 3,225 SQ-CM

1,613 SQ-CM

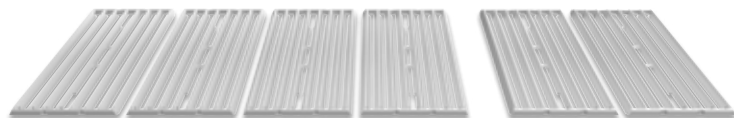

IMPERIAL™ 500 SERIES | 5,645 SQ-CM TOTAL GRILLING AREA

STAINLESS STEEL WARMING RACK - 1,613 SQ-CM



CAST STAINLESS COOKING GRIDS - 4,032 SQ-CM

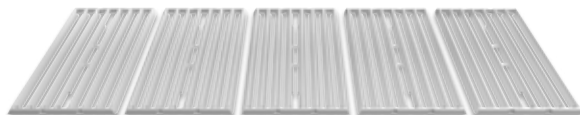

IMPERIAL™ 400 SERIES | 4,484 SQ-CM TOTAL GRILLING AREA

STAINLESS STEEL WARMING RACK - 1,258 SQ-CM



CAST STAINLESS COOKING GRIDS - 3,226 SQ-CM

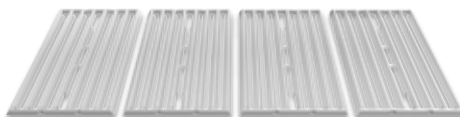

CAST STAINLESS STEEL GRIDS



GROOVED SIDE



CAST IRON SIDE BURNER

2.7 kW



STAINLESS STEEL ROTISSERIE BURNER

4.4 kW



304 STAINLESS STEEL COOK BOX



ELECTRONIC IGNITION



STAINLESS STEEL WARMING RACK



STAINLESS STEEL HANDLES



BUILT-IN OVEN LIGHTS



CONTROL KNOB LIGHTS



REGAL™ BUILT-IN STANDARD FEATURES

COOKING GRIDS	Reversible heavy-duty cast iron cooking grids
FLAVOUR SYSTEM	304 stainless steel Flav-R-Wave™ cooking system
HEAT CONTROL	Linear-Flow™ valves with 180° Sensi-Touch™ control
THERMOMETER	Deluxe Accu-Temp™ thermometer
IGNITION	Sure-Lite™ electronic ignition system
COOK BOX AND LID	304 stainless steel cook box and lid with cast aluminum end caps
LID DESIGN	Roll-action lid with cast aluminum end caps
HANDLE	Stylish and durable stainless steel handle
FINISH	Premium stainless steel finish
BUILT-IN LIGHTS	Built-in battery operated control knob lights



REGAL™ 520 BI FEATURES

PERFORMANCE	16 kW main burner output
BURNERS	Five stainless steel Dual-Tube™ burners
TOTAL COOK SPACE	5,645 sq cm total cooking space including porcelain coated warming rack
PRIMARY COOK SPACE	4,032 sq cm primary cooking space





REGAL™ 420 BI FEATURES

PERFORMANCE	12.8 kW main burner output
BURNERS	Four stainless steel Dual-Tube™ burners
TOTAL COOK SPACE	4,484 sq cm total cooking space including porcelain coated warming rack
PRIMARY COOK SPACE	3,226 sq cm primary cooking space



IMPERIAL™ S 200 BI RANGE BURNER

PERFORMANCE	5.4 kW main burner output
BURNERS	2 range burners each with individual controls
COOKING TRIVET	2 durable cast iron trivets
HEAT CONTROL	Linear-Flow™ valves with 180° Sensi-Touch™ control
IGNITION	Sure-Lite™ electronic ignition system
FINISH	Premium stainless steel finish
BUILT-IN LIGHTS	Built-in battery operated control knob lights

REGAL™ 520 | 5,645 SQ-CM TOTAL GRILLING AREA

STAINLESS STEEL WARMING RACK - 1,613 SQ-CM

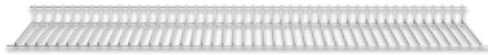

HEAVY DUTY CAST IRON COOKING GRIDS - 4,032 SQ-CM



REGAL™ 420 | 4,484 SQ-CM TOTAL GRILLING AREA

STAINLESS STEEL WARMING RACK - 1,258 SQ-CM



HEAVY DUTY CAST IRON COOKING GRIDS - 3,226 SQ-CM

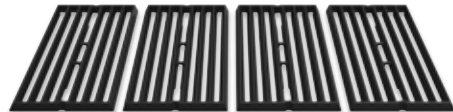

CAST IRON GRIDS - TWO SIDED



GROOVED SIDE



STAINLESS STEEL DUAL-TUBE™ BURNERS



DUAL-FLAME



STAINLESS STEEL FLAV-R-WAVE™



INFUSES GREAT FLAVOUR



304 STAINLESS STEEL COOK BOX



ELECTRONIC IGNITION



STAINLESS STEEL WARMING RACK



STAINLESS STEEL HANDLES



SLIDE-OUT GREASE TRAY SYSTEM



CONTROL KNOB LIGHTS



STAINLESS STEEL GRILL CABINETS

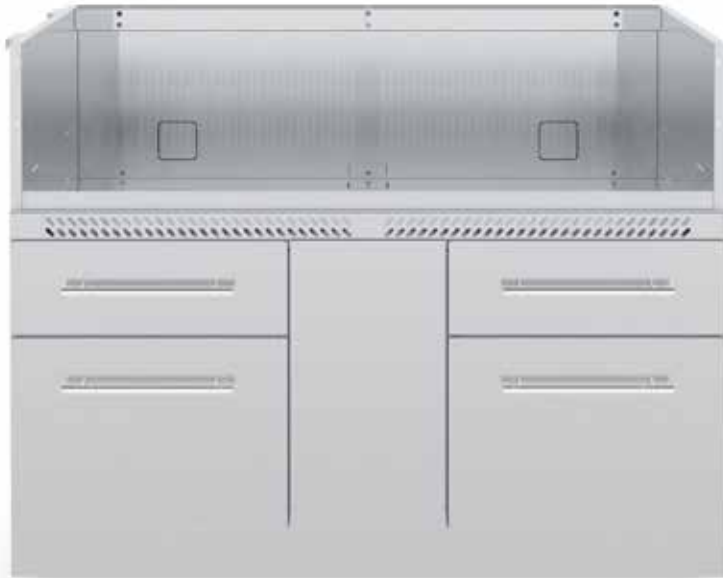

*Grill head sold separately.

6 BURNER STAINLESS STEEL CABINET

CONSTRUCTION	Premium 304 grade stainless steel
SUPPORT	Four sturdy leveling feet
STORAGE	Four stainless steel drawers Small 10.5cm x 38.52cm x 50.91cm Large 26.1cm x 38.52cm x 50.91cm
DIMENSIONS	87.5cm x 114.8cm x 75.8cm





*Grill head sold separately.

5 BURNER STAINLESS STEEL CABINET

CONSTRUCTION	Premium 304 grade stainless steel
SUPPORT	Four sturdy leveling feet
STORAGE	Four stainless steel drawers Small 10.5cm x 38.52cm x 50.91cm Large 26.1cm x 38.52cm x 50.91cm
DIMENSIONS	87.5cm x 96.2cm x 75.8cm



STAINLESS STEEL GRILL CABINETS



*Grill head sold separately.

4 BURNER STAINLESS STEEL CABINET

CONSTRUCTION	Premium 304 grade stainless steel
SUPPORT	Four sturdy leveling feet
STORAGE	Two stainless steel drawers Small 10.5cm x 73.19cm x 50.91cm Large 26.1cm x 73.19cm x 50.91cm
DIMENSIONS	87.5cm x 80cm x 75.8cm



STAINLESS STEEL RANGE BURNER CABINET

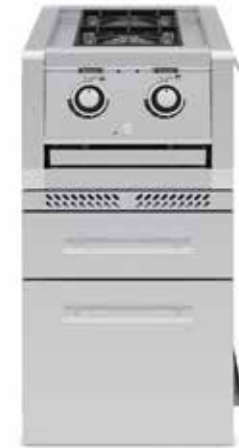

*Imperial™ S 200 Range Burner sold separately.

STAINLESS STEEL CABINET

CONSTRUCTION	Premium 304 grade stainless steel
SUPPORT	Four sturdy leveling feet
STORAGE	Two stainless steel drawers Small 10.5cm x 38.52cm x 50.91cm Large 26.1cm x 38.52cm x 50.91cm
DIMENSIONS	87.5cm x 90cm x 75.8cm



STAINLESS STEEL STORAGE CABINETS



*Sink and countertop not included.

2-DOOR STAINLESS STEEL CABINET

CONSTRUCTION	Premium 304 grade stainless steel
SUPPORT	Four sturdy leveling feet
STORAGE	Two stainless steel doors with stainless steel shelf
DIMENSIONS	87.5cm x 90cm x 75cm





*Countertop not included.

3-DRAWER STAINLESS STEEL CABINET

CONSTRUCTION	Premium 304 grade stainless steel
SUPPORT	Four sturdy leveling feet
STORAGE	Three stainless steel easy-glide drawers
DIMENSIONS	87.5cm x 45cm x 75.8cm



STAINLESS STEEL STORAGE CABINETS



*Countertop not included.

1-DOOR / DRAWER STAINLESS STEEL CABINET

CONSTRUCTION	Premium 304 grade stainless steel
SUPPORT	Four sturdy leveling feet
STORAGE	Stainless steel door with shelf / one easy-glide drawer
DIMENSIONS	87.5cm x 45cm x 75.8cm





*Countertop not included.

WASTE ORGANIZER STAINLESS STEEL CABINET

CONSTRUCTION	Premium 304 grade stainless steel
SUPPORT	Four sturdy leveling feet
STORAGE	Stainless steel door / pull-out cabinet with white trash bin and blue recycling bin included
DIMENSIONS	87.5cm x 45cm x 75.8cm



STAINLESS STEEL SIDE BURNER CABINET



*Side Burner sold separately.
*Countertop not included.

TANK / SIDE BURNER STAINLESS STEEL CABINET

CONSTRUCTION	Premium 304 grade stainless steel
SUPPORT	Four sturdy leveling feet
STORAGE	Stainless steel door with pull-out propane tank drawer
DIMENSIONS	87.5cm x 45cm x 75.8cm



STAINLESS STEEL CORNER CABINET



*Countertop not included.

90° CORNER CABINET

CONSTRUCTION Premium 304 grade stainless steel

SUPPORT Six sturdy leveling feet

DIMENSIONS 86.56cm x 68.73cm x 69.34cm



STAINLESS STEEL CABINET ACCESSORIES



CABINET SIDE PANEL

CONSTRUCTION	Premium 304 grade stainless steel
DIMENSIONS	78cm x 5cm x 75cm





REAR PANEL FEATURES

CONSTRUCTION Premium 304 grade stainless steel

REAR PANEL – 6 BURNER CABINET

DIMENSIONS 78cm x 114.8cm x 4.7cm

REAR PANEL – 5 BURNER CABINET

DIMENSIONS 78cm x 96.2cm x 4.7cm

REAR PANEL – 4 BURNER CABINET

DIMENSIONS 78cm x 80cm x 4.7cm

REAR PANEL – KEG / 2 DOOR CABINET

DIMENSIONS 78cm x 90cm x 4.7cm

REAR PANEL – SMALL CABINET

DIMENSIONS 78cm x 45cm x 4.7cm

REAR PANEL – 90° CORNER CABINET

DIMENSIONS 78cm x 45cm x 4.7cm





KEEP YOUR GRILL LOOKING LIKE NEW WITH BROIL KING® 3-STEP CLEANING SOLUTION

62381 | GRILL AND CASTING CLEANER

1

CONSTRUCTION	Non-toxic cleaning formula
DESIGN	Easily removes grease, grime and smoke stains
DIMENSIONS	500 ml



62391 | GRILL REVITALIZER

2

CONSTRUCTION	Non-toxic cream cleaner for stainless and porcelain
DESIGN	Removes the toughest grime, rust and smoke stains
DIMENSIONS	500 ml



62386 | STAINLESS STEEL CLEANER

3

CONSTRUCTION	Non-toxic cleaning formula
DESIGN	Lightly cleans and restores stainless steel shine
DIMENSIONS	500 ml



BUILT-IN ASSEMBLY HOW IT WORKS

Easy to assemble. Better to enjoy.

Simply choose your grill, burner, cabinets, outdoor kitchen accessories and countertop and you're on your way to creating your ultimate outdoor grilling center. The stainless steel cabinets come pre-assembled so all that is required is securing them together with a few fasteners.



Lift the cabinet onto the L-Bracket affixed to the adjoining bottom cabinet.



Latch the top L-Bracket from the adjoining cabinet over the cabinet and secure with screws.



PLANNING YOUR OUTDOOR KITCHEN

Find the ideal location

The first step in designing your outdoor grilling center is to survey the area. You need to determine how much space you can dedicate, then measure it. Make sure that your grilling paradise is close to accessible utilities. We recommend using at least 82 cm of clearance to ensure that you have plenty of room for food prep, cooking, serving, and entertaining.

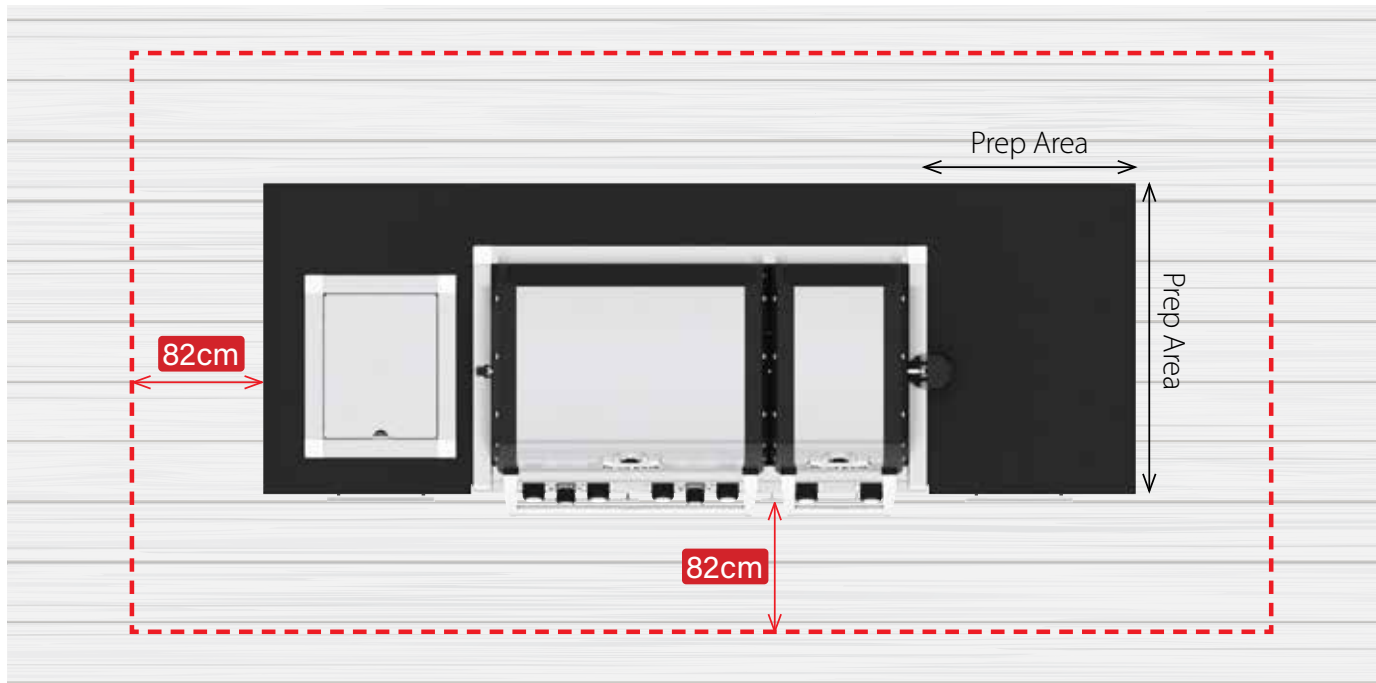

Drawing your design on paper will help you understand where you need to position things so you can get the best possible experience for you and your guests.

DETERMINE YOUR NEEDS

Entertaining Area

How much space do you have to work with on your deck or patio?

Location

Will your outdoor grilling center be against a wall or free-standing? Are there any fire risks in the area?

Water

Do you require running water? Hot and Cold? How far away is outdoor plumbing from the grilling center?

Drainage

Are you going to use the waste water system in your home? French drain or dry well? Bucket or yard drainage?

Winterizing Shut-Offs

Do you need to winterize? Where are the shut-off valves located?

Gas

Do you need to have a line installed for natural gas or are you using a propane tank?

Electrical

Where are the outlets located? Do you have the proper amperage requirements?

Shelter from the Elements

Do you need to plant trees or install awnings/ pergola to provide shade? Direction of the wind for blowing smoke?

Lighting

Where does the sun rise and set in your location? Do you need lighting around or to and from the grilling center?

Positioning the Grilling Center

Make sure to position the grill facing the wind. This will assist in venting hot air through the back of the grill.

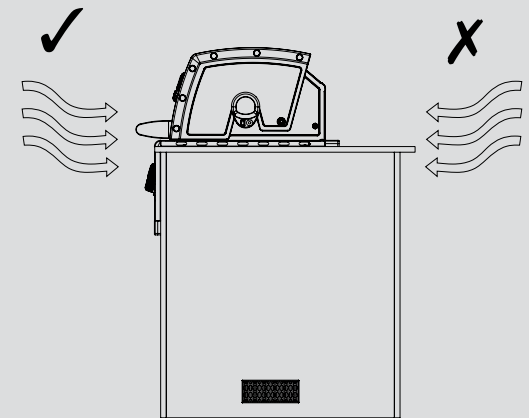

Correct position

Assists in venting hot air through the back of the grill.

Incorrect position

Disrupts airflow and reduces performance.

Please refer to the Built-In Owner's Manual for a complete guide on safety and installation.

Planning.

Using your space effectively.

Once you've determined the ideal spot for your built-in grill, decide on the size and type of grill that will be installed. The Broil King® Keg is an easy addition to any outdoor kitchen if you are looking for a Kamado-style charcoal grill. Consider any cabinet features you would like to incorporate more storage, refrigeration or dish- Consider how each appliance and cabinet will fit into the overall design, how much room to allow for each, and how they will 'flow' into each other. Having a sink and prep station nearby is good for effective food preparation and service. Also consider the seating required for guests while entertaining.

Think about grilling in all seasons.

Grilling while enjoying the sunshine is the best scenario, but having some shade to dine in can be a blessing in some locations. Incorporating a tall roof or pergola over your outdoor kitchen will allow you to enjoy cooking outdoors in all weather, and extend the seasonal opportunities of your space. If you live in a warm-climate, you may want to include an overhead fan to keep you cool on hot summer days and to keep mosquitoes at bay. If you plan on using your outdoor kitchen during the cold weather months, consider leaving space for heat lamps, a fireplace, or a roof with a built-in exhaust hood. See the Owner's Manual for exhaust installation.

The final touches.

Your outdoor grilling center is designed for you and your guests to enjoy the outdoors while having the comforts of an indoor living space. Make sure to include features that will blend with the look and feel of your home. Adding chairs to your grilling center creates a focal point when entertaining. Decorative lighting enhances the experience at night along with propane heaters to keep your guests comfortable. Choose durable outdoor furniture with comfortable cushions. Select a table for your space for dining or as a buffet.

DIY or expert installation.

Consider what you are capable of by yourself. Simple installations involving propane fueled grills and minor landscaping might be attainable on your own. If your grilling center involves natural gas lines, electricity, water and major landscaping, it's best to hire professionals that know all of the necessary building codes and safety regulations.

Built-In Cut-Out Dimensions.

BROIL KING® IMPERIAL™ 590 BUILT-IN CABINET

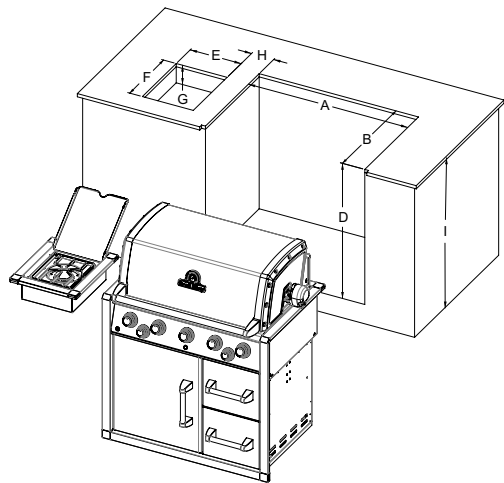

BROIL KING® IMPERIAL™ 590 BUILT-IN

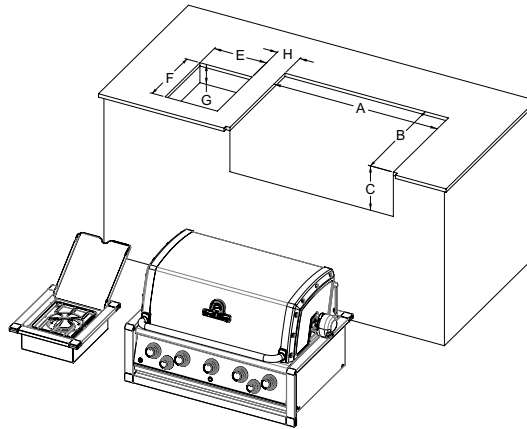

BROIL KING® IMPERIAL™ S 200 RANGE BURNER

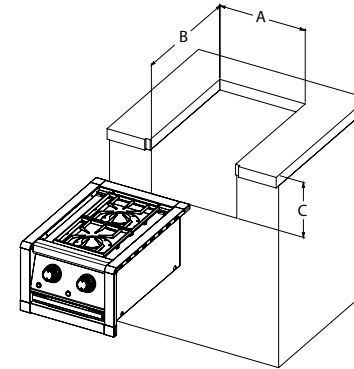

COUNTERTOP NOTCH DETAIL

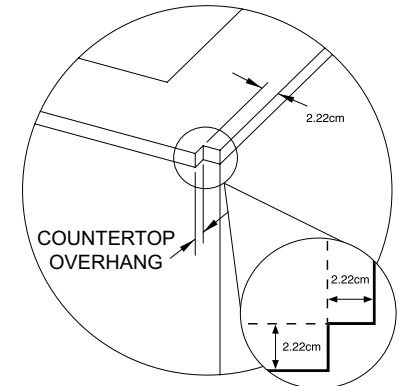

ISLAND CUT-OUT DIMENSIONS

	BROIL KING® IMPERIAL™ S 690/670	BROIL KING® IMPERIAL™ S 590/570 REGAL™ 520	BROIL KING® IMPERIAL™ S 490/470 REGAL™ 420	IMPERIAL™ S 200 RANGE BURNER
A	MIN. 110.80 CM MAX. 111.44 CM	MIN. 92.07 CM MAX. 92.71 CM	MIN. 75.88 CM MAX. 76.51 CM	MIN. 41.5 CM
B		MIN. 58.73 CM	MAX. 59.37 CM	
C		MIN. 25.71 CM	MAX. 26.35 CM	
D		MIN. 80.01 CM	MAX. 80.64 CM	
E		MIN. 29.21 CM	MAX. 29.84 CM	
F		MIN. 36.83 CM	MAX. 37.46 CM	
G		MIN. 11.43 CM		
H		MIN. 7.62 CM	MAX. 17.78 CM	
I		MIN. 86.36 CM		

PROTECT MORE PREMIUM GRILL COVERS

Keep your grill looking its best. Crafted from water resistant PVC with a heavy woven 900D polyester backing, these premium covers feature a retention system for a secure fit. Blue accent stitching adds style to the extra reinforced seams. Molded rubber handles make the cover easy to remove. Well-crafted covers to protect well-built grills!



PART #	MODEL
68590	BROIL KING® IMPERIAL™ 600 SERIES
68592	BROIL KING® IMPERIAL™ / REGAL™ 500 SERIES
68591	BROIL KING® IMPERIAL™ / REGAL™ 400 SERIES



THE TIE-CORD EASILY SECURES TO BUILT-IN UNIT



FLASHING DIRECTS WATER AWAY FROM GRILL



SNUG-FIT VELCRO ADJUSTMENT



DURABLE MOLDED RUBBER HANDLES



ENJOY MORE THE ESSENTIALS

60975 | GRILLING APRON



Easy to adjust neck / waist strap with buckle.

Thermometer pocket.

Blue accent stitching.

Includes a bottle opener.

Five convenient pockets for lots of grilling essentials.

Easy to clean water resistant PVC exterior with polyester interior.



62602 | RIB RACK AND ROAST SUPPORT

MATERIAL	Stainless steel, 10 mm and 5 mm
DESIGN	Accommodates 7 racks of ribs, holds roasts too
DIMENSIONS	38.5 cm x 21.8 cm x 10.2 cm



69814 | OVERSIZED GRILLING STONE

MATERIAL	Extra thick 1.9 cm ceramic stone
DESIGN	Amazing heat retention, durable ceramic compound
DIMENSIONS	28 cm diameter



64003 | BARON™ GRILL TOOLS

CONSTRUCTION	Durable resin handles and stainless blades
DESIGN	Durable shafts, silicone basting brush
FEATURES	Turner, locking tong, basting brush and grill brush



61825 | INSTANT READ THERMOMETER

MATERIAL	Stainless probe, durable resin body, stainless fascia
DESIGN	Fast reading intervals with back lit screen
DIMENSIONS	20.32 cm



60938 | DELUXE GRILL LIGHT AND TIMER

MATERIAL	Resin body, LCD display
DESIGN	COB light strips with integrated cooking timer
DIMENSIONS	25.4 cm



61935 | SIDE TABLE THERMOMETER

MATERIAL	Stainless probes, durable resin body, stainless fascia
DESIGN	Two probes, countdown timer, target temperature
DIMENSIONS	12.7 cm



60974 | INSULATED MITT

MATERIAL	Heat resistant aramid exterior with silicone grip
DESIGN	Flexible, high heat resistant glove
DIMENSIONS	One size fits most, one mitt



See more great
Broil King® accessories
broilkingbbq.com

EXPLORE MORE CLEANING ALTERNATIVES

65600 | COIL SPRING BRUSH



Each coil spring moves independently to efficiently remove food residue

High density resin handle with embossed Broil King® logo



Quick and easy click-in replacement brush head

Durable stainless steel shaft

PATENT PENDING



48 durable stainless steel coil springs for optimal cleaning

High density resin brush head



Patented design.



65643 | EXTRA WIDE NYLON GRILL BRUSH

MATERIAL	Stiff nylon bristles, resin handle
DESIGN	Cleans deep into the corners of the grill and between grids
DIMENSIONS	47.8 cm x 20.3 cm

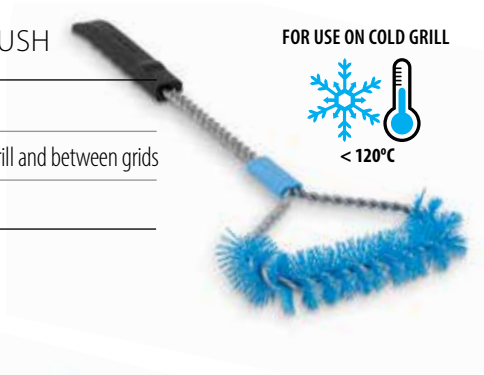

65335 | WOOD GRILL SCRAPER

CONSTRUCTION	Wooden body, stainless steel hanger
DESIGN	Wooden grill scraper with power grip
DIMENSIONS	45.7 cm



65648 | EXTRA WIDE PALMYRA GRILL BRUSH

CONSTRUCTION	Durable palmyra leaf bristles, resin handle
DESIGN	Cleans deep into the corners of the grill and between grids
DIMENSIONS	47.8 cm x 20.3 cm



64038 | BARON™ PALMYRA GRILL BRUSH

CONSTRUCTION	1.2 mm stainless steel, durable resin handle
DESIGN	Durable palmyra leaf bristles, replaceable brush head
DIMENSIONS	44.7 cm x 7.6 cm



64658 | BARON™ PALMYRA BRUSH HEADS (3)

CONSTRUCTION	Durable resin base with palmyra leaf bristle
DESIGN	3-Pack replaceable brush heads
DIMENSIONS	8.9 cm x 5.7 cm



FRESH CLEANING ALTERNATIVES

These Broil King® cleaning solutions are a fresh way to revitalize your grill inside and out. Proper grill care is critical for great tasting food. A clean grill performs better, has fewer flare ups and doesn't come with any unwanted flavours.





IMPERIAL[®] S 690 - BUILT-IN
997483 LP / 997486 NG



IMPERIAL[®] S 590 - BUILT-IN
998483 LP / 998486 NG



IMPERIAL[®] S 490 - BUILT-IN
996483 LP / 996486 NG



6 BURNER CABINET
807600



IMPERIAL[®] S 690 - BUILT-IN
997083 LP / 997086 NG



IMPERIAL[®] S 590 - BUILT-IN
998083 LP / 998086 NG



IMPERIAL[®] S 490 - BUILT-IN
996083 LP / 996086 NG



2 DOOR CABINET
804200



IMPERIAL[®] S 670 - BUILT-IN
997073 LP / 997076 NG



IMPERIAL[®] S 570 - BUILT-IN
998073 LP / 998076 NG



IMPERIAL[®] S 470 - BUILT-IN
996073 LP / 996076 NG



90° CORNER CABINET
803900



REGAL[™] S520 - BUILT-IN
886653 LP / 886656 NG



REGAL[™] S420 - BUILT-IN
985653 LP / 996056 NG



IMPERIAL[®] S 200 - RANGE BURNER
802873 LP



REAR PANEL SMALL CABINET
802060



5 BURNER CABINET
806600



4 BURNER CABINET
805600



KEG CABINET
804600



S 200 RANGE BURNER CABINET
802400



DOUBLE DOOR KIT
900820



3 DRAWER CABINET
802500



TANK/SIDE BURNER CABINET
802700



1 DOOR/DRAWER CABINET
802300



WASTE ORGANIZER CABINET
802800



REAR PANEL 6 BURNER CABINET
807060



REAR PANEL 5 BURNER CABINET
806060



REAR PANEL 4 BURNER CABINET
805060



REAR PANEL KEG / 2 DOOR CABINET
804060



REAR PANEL CORNER CABINET
803060



REAR PANEL 24-IN COMPACT FRIDGE
800040



REAR PANEL 22-IN COMPACT FRIDGE
800030



CABINET SIDE PANEL
FITS ALL CABINETS
800050



Broil King
Great Barbecues Every Time